

Turmdrehkran L1-24

Tower Crane / Grue à tour / Gru a torre / Grúa torre /
Guindaste de torre / Башенный поворотный кран

25 m
27 m

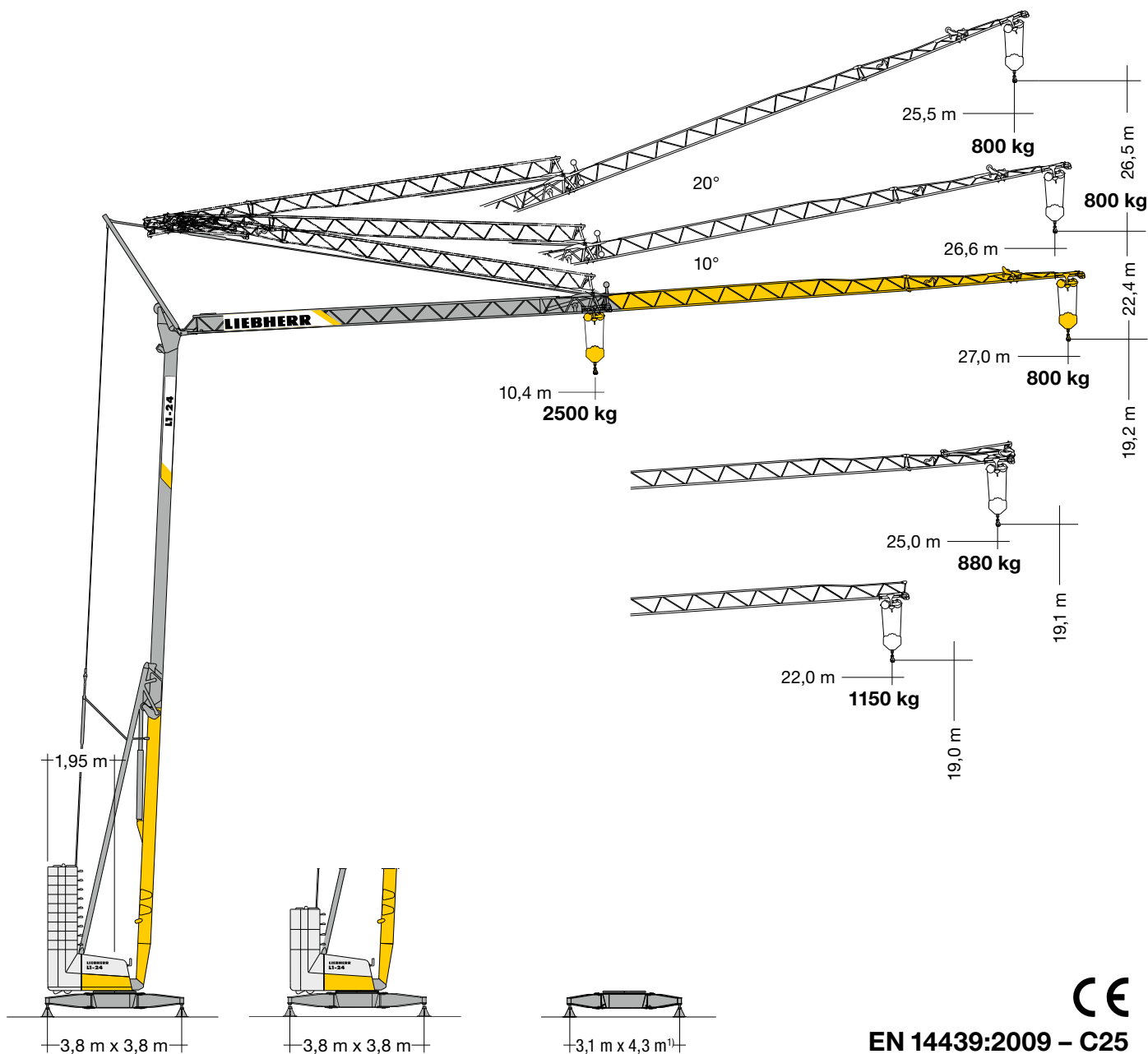

EN 14439:2009 - C25

LIEBHERR

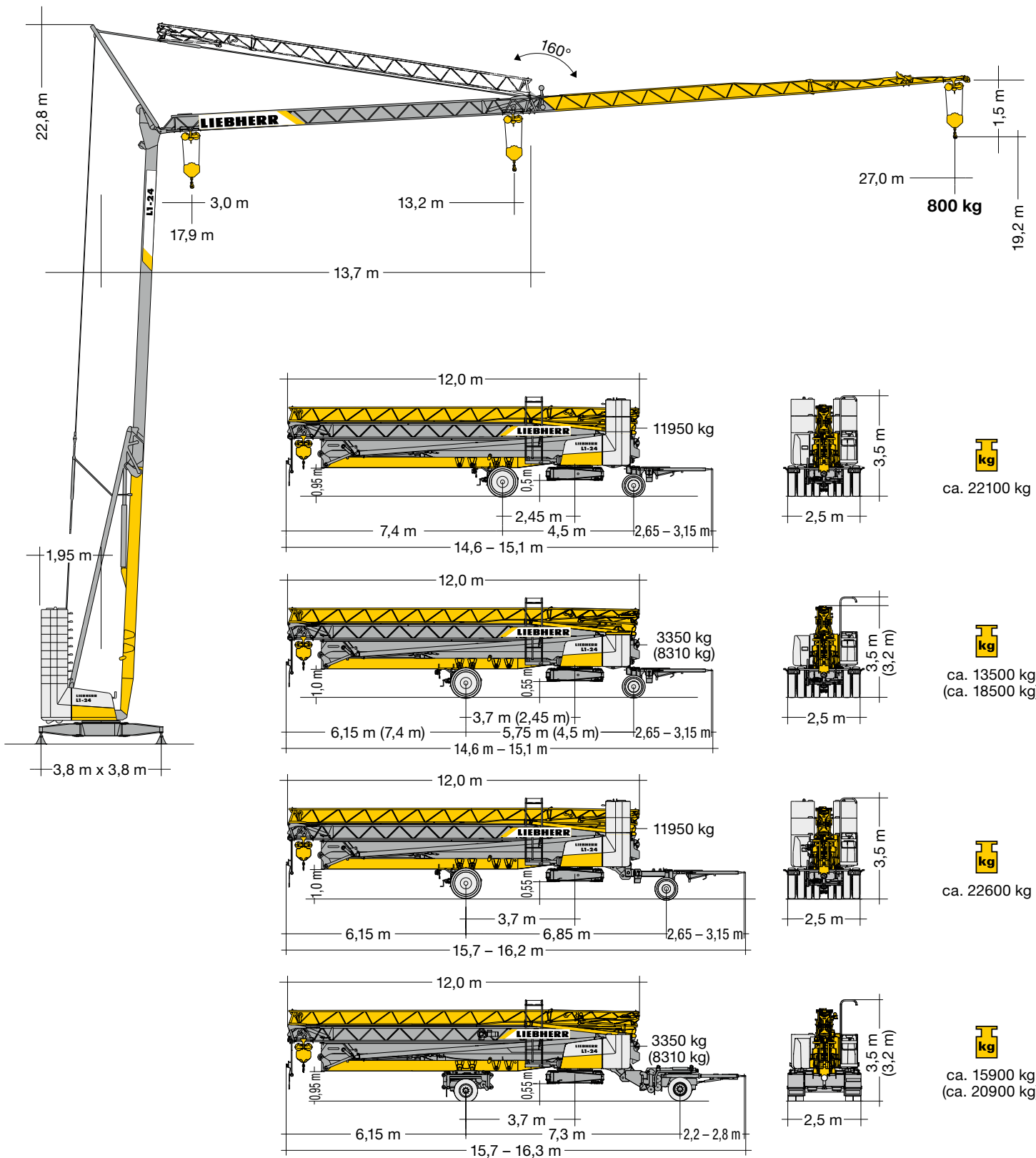

Gewicht Weight/Poids/Peso/Peso/Pesos/Macca

	11.950 – 12.950 kg ¹⁾	r = 1,95 m		8200 kg
	15.230 – 15.350 kg ¹⁾			

Ausladung und Tragfähigkeit

Radius and capacity / Portée et charge / Sbraccio e portata / Alcances y cargas / Alcance e capacidade de carga / Вылет и грузоподъемность



m	m/kg	m/kg																		
		10,0	11,0	12,0	13,0	13,2	14,0	15,0	16,0	17,0	18,0	19,0	20,0	21,0	22,0	23,0	24,0	25,0	26,0	27,0
27,0	3,0 – 10,4 2500	2500	2400	2090	1890	1860	1730	1600	1480	1370	1280	1200	1130	1070	1010	960	920	870	830	800
25,0	3,0 – 10,4 2500	2500	2410	2100	1900	1870	1740	1600	1480	1380	1290	1210	1140	1080	1020	970	920	880		
22,0	3,0 – 11,4 2500	2500	2500	2350	2130	2100	1960	1800	1660	1550	1450	1360	1280	1210	1150					
13,2	3,0 – 9,6 2500	2430	2150	1920	1730	1700														

m	m/kg	Auslegersteilstellung 10° / Elevated jib 10° / Flèche inclinée 10° / Braccio inclinato a 10° / Pluma inclinada 10° / Lança inclinada 10° / Положение стрелы под углом 10°																			
		10,0	11,0	12,0	13,0	13,1	14,0	15,0	16,0	17,0	18,0	19,0	20,0	21,0	21,7	23,0	24,0	24,6	25,0	26,0	26,6
27,0	3,0 – 14,1 1700	1700	1700	1700	1700	1700	1700	1570	1450	1350	1260	1180	1110	1050	1000	950	900	870	860	820	800
25,0	3,0 – 14,1 1700	1700	1700	1700	1700	1700	1700	1570	1460	1360	1270	1190	1120	1060	1020	950	900	880			
22,0	3,0 – 15,6 1700	1700	1700	1700	1700	1700	1700	1700	1640	1530	1420	1340	1270	1190	1150						
13,2	3,0 – 13,1 1700	1700																			

m	m/kg	Auslegersteilstellung 20° / Elevated jib 20° / Flèche inclinée 20° / Braccio inclinato a 20° / Pluma inclinada 20° / Lança inclinada 20° / Положение стрелы под углом 20°																		
		10,0	11,0	12,0	12,4	13,0	14,0	15,0	16,0	17,0	18,0	19,0	20,0	20,7	21,0	22,0	23,0	23,6	24,0	25,0
27,0	3,0 – 25,5 800	800																		
25,0	3,0 – 23,6 880	880																		
22,0	3,0 – 20,7 900	900																		
13,2	3,0 – 12,4 900	900																		

Antriebe

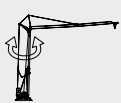
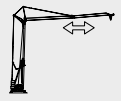
Driving units / Mécanismes d'entraînement / Meccanismi / Mecanismos / Mecanismos / Приводы

	230 V ¹⁾	400 V	
	0 ↔ U/min 0,5 sl./min tr./min	0 ↔ U/min 0,8 sl./min tr./min	1,5 kW FU
	0 ↔ 22,0 m/min	0 ↔ 40,0 m/min	2,0 kW FU
	ca. 160°/min.	ca. 160°/min.	1,5 kW

BGL		C.0.02.0022
-----	---	-------------

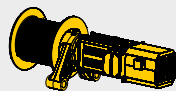
 ↔ **stufenlos / stepless / régl. continu / regl. progressiva / sin escalones / sem degraus / бесступенчатый**

kg m/min

7,5 kW FU

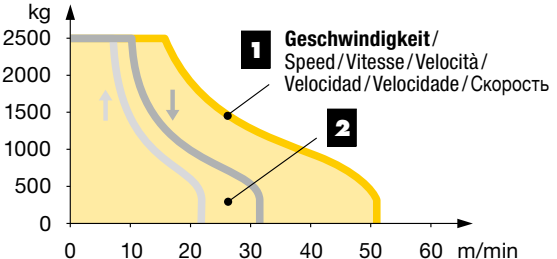

 **Geschwindigkeit**
Speed **400 V**
Vitesse **1** 2500 0 ↔ 16,0
Velocità **1** 300 0 ↔ 51,0
Velocidad **230 V¹⁾**
Velocidade **2** 2500 0 ↔ 7,0 ↑/10,0 ↓
Скорость **2** 300 0 ↔ 22,0 ↑/32,0 ↓

400 V
230 V¹⁾



1 Geschwindigkeit / Speed / Vitesse / Velocità / Velocidad / Velocidade / Скорость

2

	230 V	50 Hz	16,0 A
	400 V	50 Hz	11,0 kVA

¹⁾ siehe Betriebsanleitung. / see instruction manual. / voir manuel de service. / vedi manuale d'istruzione. / ver manual de instrucción. / ver manual de instruções. / см. инструкцию по эксплуатации.

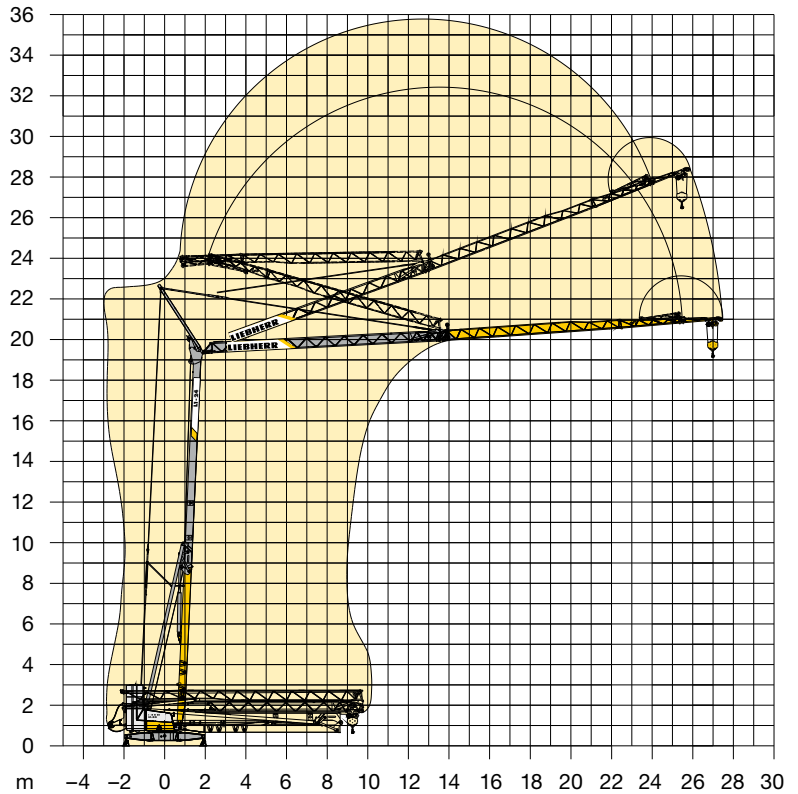

Kolli-Liste

Packing List / Liste de colisage / Lista dei colli /
Lista de contenido / Lista de embalagem / Упаковочный лист

Pos.	Anz.				L (m)	B (m)	H (m)	kg	
1	1	Transportachse vorne L1-Adapter / Road transport axle front / Essieux de transport avant / Asse di trasporto anteriore / Eje delantero para transporte / Eixo de transporte dianteiro / Транспортировочная ось, передняя	Tra 100 KY 2			3,09	1,24	1,36	600
			Tra 100 KY 6			3,09	1,24	1,36	700
			Tra 100 KY 6 A			3,09	1,24	1,36	700
2	1	Transportachse vorne, H-Adapter / Road transport axle front, H adapter / Essieux de transport avant, pièce d' adapt. H / Assale anteriore, adattatore per H / Eje de transporte delantero, adaptador H / Eixo de transporte dianteiro, adaptador H / Транспортировочная ось, передняя, адаптер	Tra 100 KY 2			4,30	1,25	1,31	750
			Tra 100 KY 6			4,30	1,25	1,31	850
			Tra 100 KY 6 A			4,30	1,25	1,31	850
3	1	Transportachse vorne m. Zwischenadapter / Road transport axle front w. adapter / Essieux de transport avant a. pièce d' adapt. / Assale anteriore con adattatore intermedio / Eje de transporte delantero con adaptador intermedio / Eixo de transporte dianteiro com adaptador intermédio / Транспортировочная ось, передняя, с промежуточным адаптером	Tra 100 KY 2			4,30	1,25	1,31	950
			Tra 100 KY 6			4,30	1,25	1,31	1200
			Tra 100 KY 6 A			4,30	1,25	1,31	1200
4	1	Transportachse hinten, H-Adapter / Road transport axle behind, H adapter / Essieux de transport arrière, pièce d' adapt. H / Assale posteriore, adattatore per H / Eje de transporte trasero, adaptador H / Eixo de transporte traseiro, adaptador H / Транспортировочная ось, задняя, адаптер	Tra 120 GY 1			1,60	2,50	1,20	1000
			und/and/et/ e/y/y GY 1 A			1,60	2,50	1,20	1000
5	1	Transportachse hinten m. Zwischenadapter / Road transport axle behind w. adapter / Essieux de transport arrière a. pièce d' adapt. / Assale posteriore con adattatore intermedio / Eje de transporte trasero con adaptador intermedio / Eixo de transporte traseiro com adaptador intermédio / Транспортировочная ось, задняя, с промежуточным адаптером	Tra 120 GY 1			1,75	2,50	1,25	1250
			und/and/et/ e/y/y GY 1 A			1,75	2,50	1,25	1250
6	1	Transportachse vorne LiTRAX HS-121 / Road transport axle front / Essieux de transport avant / Asse di trasporto anteriore / Eje delantero para transporte / Eixo de transporte dianteiro / Транспортировочная ось, передняя				3,65 – 4,25	2,10	1,15	1900
7	1	Transportachse hinten LiTRAX HS-122 (ohne Lenkung) / Road transport axle behind (without steering) / Essieux de transport arrière (sans direction) / Asse di trasporto posteriore (senza sterzo) / Eje trasero para transporte (sin sistema de dirección) / Eixo de transporte traseiro (sem esterço) / Транспортировочная ось, задняя (без управления)				1,95	2,50	1,10	1600
8	1	Transportachse hinten LiTRAX HS-123 (mit Lenkung) / Road transport axle behind (with steering) / Essieux de transport arrière (avec direction) / Asse di trasporto posteriore (con sterzo) / Eje trasero para transporte (con sistema de dirección) / Eixo de transporte traseiro (com esterço) / Транспортировочная ось, задняя (с управлением)				1,95	2,50	1,10	1700

Änderungen vorbehalten! / Subject to technical modifications! /
Sous réserves de modifications! / Con riserva di modifiche! /
¡Sujeto a modificaciones sin previo aviso! / Sujeto a modificaciones! /
С правом внесения изменений!

Sämtliche Angaben erfolgen ohne Gewähr. / This information is supplied without liability. /
Ces renseignements sont sans garantie. / Tutte le indicazioni fornite senza garanzia. /
Declinamos toda responsabilidad derivada de la información proporcionada. / Declinamos
qualquer responsabilidade quanto à informação fornecida. / Все данные указаны без обязательств.

TCS-000902-LBC-02 • EN 14439:2009 – A3 • BGL C.0.02.0022 • 04.19

Printed in Germany.

Liebherr-Werk Biberach GmbH
Postfach 1663, D-88396 Biberach an der Riss
☎ +49 73 51 41-0, Fax: +49 73 51 41 22 25
www.liebherr.com, E-Mail: info.lbc@liebherr.com

Liebherr Industrias Metálicas, S.A.
Polígono Industrial Agustinos, calle E, E-31014 Pamplona
☎ +34 94829 70-00, Fax +34 94829 70-29
www.liebherr.com, E-Mail: info.lim@liebherr.com